

MIC PROTECTOR®

ATP® Studio Line

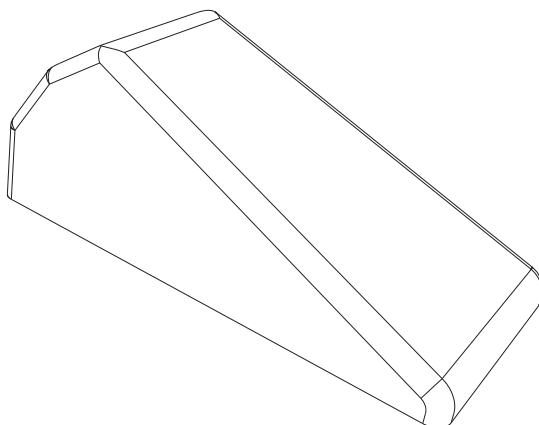

Features:

- * Insulation protector for microphones.
- * Acoustically separates sound capturing.
- * Fits most microphone models.
- * Installation: on a microphone tripod.
- * Packaging: box with 1 or 4 units.
- * Use: at live and in studio.
- * Dimensions: 220 x 110 x 85 mm.
- * Colour: gray, transparent and glossy.

Plastic colours:



This accessory is more useful to sound engineers and technicians than to musicians themselves.

This accessory is original, unique, highly necessary and in high demand. It is often used by sound engineers to improvise and make bricolage, when they need to use

something that produces this insulation effect while capturing several instruments that are close to each other. The MP1® surrounds the microphone individualising the sound that is captured.

Especially at live events, it modifies the insert's behaviour of "noise gates, compressors, dynamics' controllers" and provides them with better autonomy and easiness of control.

It is ideal to use under and over snare drums, as well as floor toms, jazz bass drums, guitar amplifiers, basses and wherever each one's imagination will dictate.

